

THE EZ CARD 10/100

SMC's EZ Card™ 10/100 is a combo 10BASE-T/100BASE-TX and 10BASE2 network interface card for PCI local bus compliant computers. A true plug-and-play device, this card is auto-configurable upon power up and supports Auto-Negotiation on the RJ-45 port to automatically select the optimum speed and communication mode of an attached device.

The EZ Card 10/100 complies with ACPI and OnNow/PC98 and also supports Remote LAN Wakeup. By connecting the EZ Card's Wake-On-LAN (WOL) cable, a WOL-enabled computer can be managed remotely. Software can be loaded and updated, configurations changed, data backed up and inventory checked, all from a central location. See "Remote LAN Wakeup."

Features and Benefits

- Conforms to IEEE 802.3 and 802.3u standards
- Compatible with PCI Local Bus Specification Rev. 2.2
- PCI 32-bit Bus-Master architecture provides high data throughput
- Single 10/100 Mbps RJ-45 port for easy migration from Ethernet to Fast Ethernet
- Supports full-duplex operation for up to 200 Mbps of bandwidth
- Auto-Negotiation for automatic selection of data rate (10/100 Mbps) and mode (half/full duplex)
- BNC connector supports connection to legacy 10BASE2 networks
- Automatic configuration setup using the PCI computer's BIOS setup program
- Supports Remote LAN Wakeup for efficient centralized desktop management
- Supports optional boot ROM for remote booting of a PC's operating system
- ACPI and OnNow/PC98 compliance reduces PC power consumption

Hardware Description

The EZ Card 10/100 is equipped with :

- 1 10BASE-T/100BASE-TX RJ-45 port
- 1 10BASE2 BNC connector
- 1 3-pin connector for Wake-On-LAN cable
- 1 Socket for optional boot ROM
- 3 LED indicators

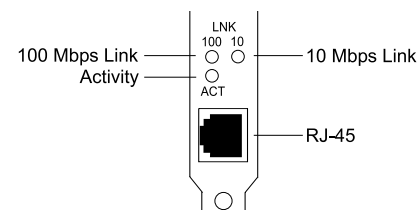
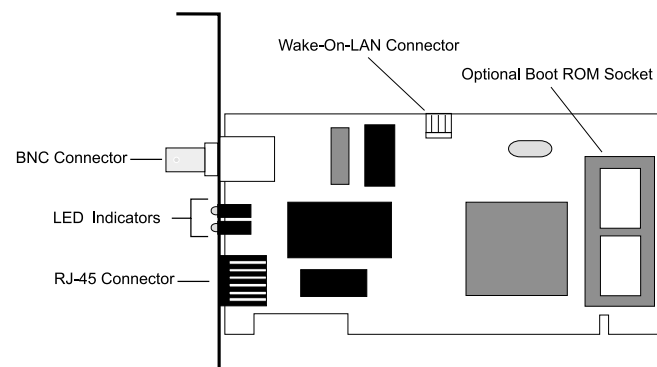

The following table describes the operation of the EZ Card 10/100 status LEDs:

LED	Condition	Status	
LNK	10	Green	Indicates a valid 10BASE-T link.
	100	Green	Indicates a valid 100BASE-TX link.
ACT	Green	Heavy network activity.	
	Blinking	Intermittent or light network activity (the blinking rate is proportional to the amount of network traffic).	

INSTALLATION

Equipment Checklist

After unpacking the EZ Card 10/100, check the contents of the box to be sure you've received the following components:

- EZ Card 10/100 SMC1211BTX/WL
- SMC SuperDisk™ driver installation diskette
- Wake-On-LAN cable
- SMC Warranty Registration Card
- This User Guide

Immediately inform your dealer in the event of any incorrect, missing or damaged parts. If possible, please retain the carton and original packing materials in case there is a need to return the product.

Note that new or updated driver information is available via SMC's Web site. To order the optional boot ROM, SMC1211-RPL, contact your local SMC dealer or reseller.

Please fill out and return the Warranty Registration Card to SMC. The EZ Card 10/100 is covered by a limited lifetime warranty.

Instructions

WARNINGS:

- Network cards are sensitive to static electricity. To protect the card, avoid touching its electrical components and always touch the metal chassis of your computer before handling the card.
- Backup your SuperDisk driver diskette and use the copy as the working diskette to protect the original from accidental damage.

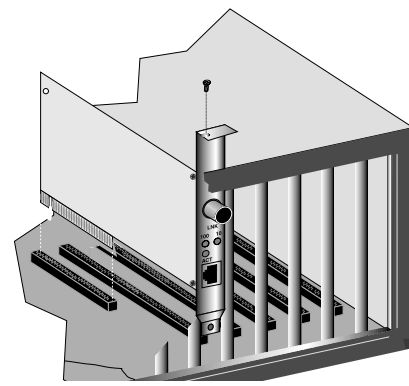

1. To install the EZ Card 10/100, power off your PC and remove the chassis cover. Next, select an unused PCI expansion bus slot and remove its protective bracket. Carefully insert the card and press until all the edge connectors are firmly seated inside the slot. Then, screw the card's bracket securely into the PC's chassis.

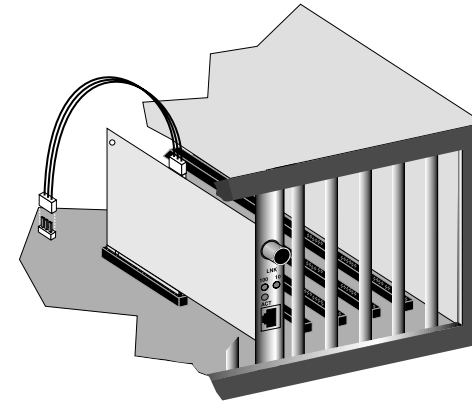

2. Attach the Wake-On-LAN cable (optional). If you require Wake-On-LAN capability, attach one end of the 3-pin Wake-On-LAN cable to the connector on the top edge of the card, and the other end to the "5V Standby" connector on the computer's motherboard. Refer to your computer's installation manual to locate this connector.

3. Connect the EZ Card 10/100 directly to a 10BASE-T or 100BASE-TX hub or switch, or to a 10BASE2 thin coax segment. Use UTP cable (Category 3, 4 or 5 for 10BASE-T; Category 5 for 100BASE-TX) for connecting to the RJ-45 port, and thin coax cable (RG-58A/U or RG-58C/U) for connecting to the BNC connector. See "Cable Specifications" for more information.

4. Replace the chassis cover on your PC and power on.

5. The EZ Card 10/100 should be automatically configured by the host computer's BIOS. However, if you have an older computer, you may have to manually configure the computer's BIOS settings.

6. The SMC SuperDisk that accompanies the EZ Card 10/100 contains all the network operating system drivers supported by this card. For convenience, the Windows 95/98 and Windows NT drivers are placed in the diskette's root directory. Please read the "RELEASE.TXT" file on the diskette for a list of all drivers. A text file is included with each driver to detail the proper installation procedure. Any new or updated drivers can be downloaded from SMC's Web site (see the back cover of this guide).

Setup Program

If the EZ Card 10/100 is not automatically configured by the host PC, or there is some problem with the card, run the DOS-based Setup Program to help configure the PC's BIOS settings and test the card.

1. Boot the computer to a full DOS environment (not a DOS window) and run the the Setup Program, SET1211.EXE, on the SMC SuperDisk. The screen will display the Main Menu (see below).

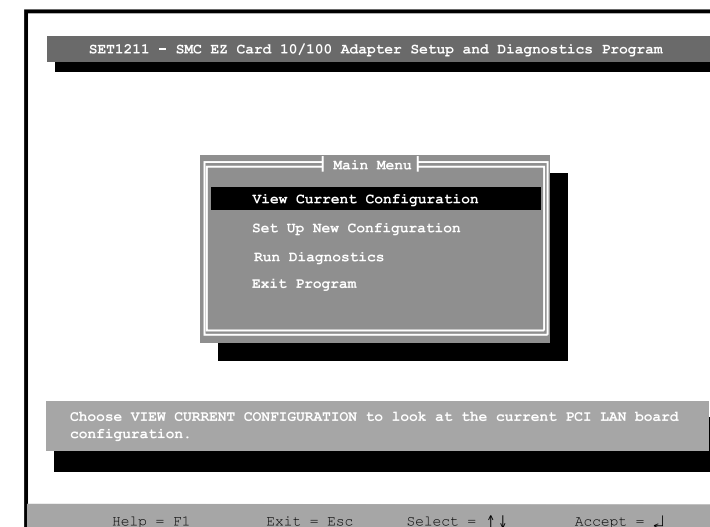

2. Select the "View Current Configuration" option from the Main Menu to access the screen shown below. If you wish to modify the current configuration, return to the Main Menu and select "Setup New Configuration".

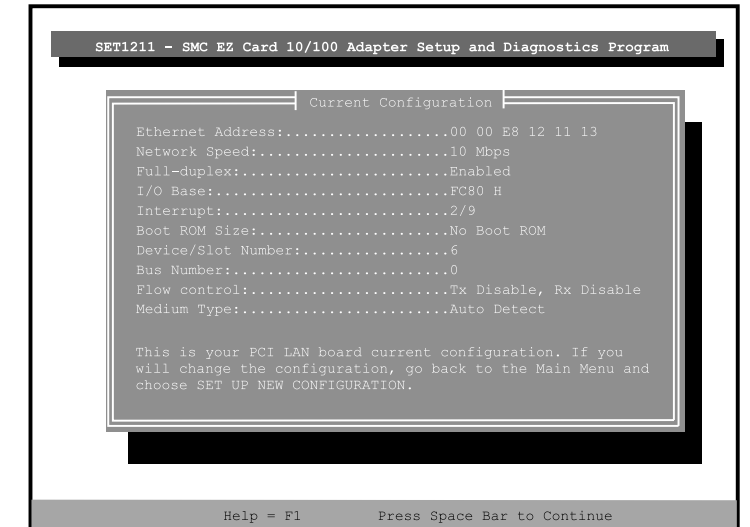

3. The host computer's BIOS automatically allocates the necessary resources, such as the Interrupt and I/O Base, to the EZ Card 10/100. Although the Setup Program will not allow you to change those resources, you can change the settings displayed on the "Setup New Configuration" screen (see below).

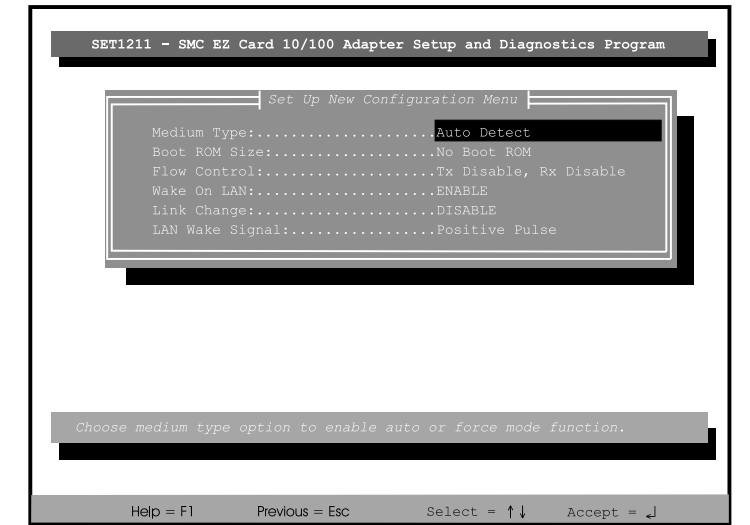

4. In the event of a problem with the EZ Card 10/100, use the Setup Program to run the card's built-in diagnostics (see the "SET1211.TXT" file for specific instructions). Should any of the diagnostic tests fail, reboot your computer and run the diagnostics again to see if the problem persists. If it does, record the failure indicated and contact SMC's Tech Support for assistance (see the back cover of this guide).

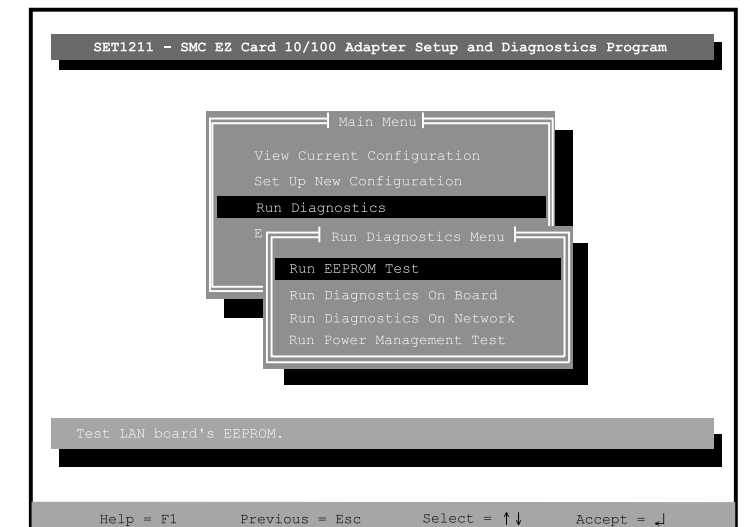

- ◆ 10BASE-T/100BASE-TX or 10BASE2 connection options
- ◆ Support for full-duplex operation with Auto-Negotiation
- ◆ Plug-and-play installation
- ◆ Remote LAN Wakeup support
- ◆ On-board socket for optional boot ROM
- ◆ ACPI and OnNow/PC98 compliant

10/100 Mbps Fast Ethernet PCI Network Card

EZ Card 10/100

FOR TECHNICAL SUPPORT, CALL:

From U.S.A. and Canada (8:30 AM - 8:00 PM Pacific Time)
(800) SMC-4-YOU; (949) 707-2400; (949) 707-2460 (Fax)
From Europe (8:00 AM - 5:30 PM UK Greenwich Mean Time)
44 (0) 1344 420068; 44 (0) 1344 418835 (Fax)

INTERNET

E-mail addresses:
techsupport@smc.com
Driver updates:
http://www.smc.com/support.html
SMC Forum on CompuServe:
At the prompt (!) type: GO SMC
World Wide Web:
http://www.smc.com/
FTP Site:
ftp.smc.com

FOR LITERATURE OR ADVERTISING RESPONSE, CALL:

U.S.A. and Canada:	(800) SMC-4-YOU;	Fax (949) 707-2460
Europe:	44 (0) 1344 418800;	Fax 44 (0) 1344 418828
Northern Europe:	44 (0) 1344 418820;	Fax 44 (0) 1344 418826
Southern Europe:	33 (1) 41.38.32.32;	Fax 33 (1) 41.38.01.58
Central/Eastern Europe:	49 (0) 89 92861-0;	Fax 49 (0) 89 92861-230
Nordic:	46 (8) 564 33145;	Fax 46 (8) 87 62 62
Middle East:	971-4818410;	Fax 971-4817993
South Africa:	27 (0) 11-3936491;	Fax 27 (0) 11-3936491
PRC:	86-10-6235-4958;	Fax 86-10-6235-4962
Taiwan:	886-2-2748-3945;	Fax 886-2-2748-3942
Asia Pacific:	(65) 336 1800;	Fax (65) 339 6625
Korea:	82-2-553-0860-1;	Fax 82-2-553-7202-3
Japan:	81 (3) 57212271;	Fax 81 (3) 57212270
Australia:	61-2-9416-0437;	Fax 61-2-9416-0474
India:	91-22-8204437;	Fax 91-22-8204443

COPYRIGHT

Information furnished by SMC Networks, Inc. (SMC) is believed to be accurate and reliable. However, no responsibility is assumed by SMC for its use, nor for any infringements of patents or other rights of third parties which may result from its use. No license is granted by implication or otherwise under any patent or patent rights of SMC. SMC reserves the right to change specifications at any time without notice.

Copyright © 1999 by
SMC Networks, Inc.
6 Hughes, Irvine, CA 92618
All rights reserved. Printed in Taiwan

TRADEMARKS

SMC is a registered trademark; and EZ Card and SuperDisk are trademarks of SMC Networks, Inc. Other product and company names are trademarks or registered trademarks of their respective holders.

LIMITED WARRANTY

Complete warranty information for all SMC products is available on SMC's Web site at <http://www.smc.com>.

COMPLIANCES

FCC Class B

This equipment has been tested and found to comply with the limits for a Class B digital device, pursuant to Part 15 of the FCC Rules. These limits are designed to provide reasonable protection against harmful interference in a residential installation. This equipment generates, uses and can radiate radio frequency energy and, if not installed and used in accordance with instructions, may cause harmful interference to radio communications. However, there is no guarantee that the interference will not occur in a particular installation. If this equipment does cause harmful interference to radio or television reception, which can be determined by turning the equipment off and on, the user is encouraged to try to correct the interference by one or more of the following measures:

- Reorient the receiving antenna
- Increase the separation between the equipment and receiver
- Connect the equipment into an outlet on a circuit different from that to which the receiver is connected
- Consult the dealer or an experienced radio/TV technician for help

EC Conformance Declaration

The SMC contact for these products in Europe is:
SMC (Europe) Limited
1st Floor, Pyramid House, Easthampstead Road
Bracknell, Berkshire RG12 1NS, United Kingdom

This information technology product complies with the requirements of the Low Voltage Directive 73/23/EEC and the EMC Directive 89/336/EEC.

Industry Canada - Class B

This digital apparatus does not exceed the Class B limits for radio noise emissions from digital apparatus set out in the Radio Interference Regulations of Industry Canada.

Le présent appareil numérique n'émet pas de bruits radio-électriques dépassant les limites applicables aux appareils numériques de la classe B prescrites dans le Règlement sur le brouillage radioélectrique édicté par l'Industrie.

VCCI Class B

この装置は、情報処理装置等電波障害自主規制協議会（VCCI）の基準に基づくクラスB情報技術装置です。この装置は、家庭環境で使用することを目的としていますが、この装置がラジオやテレビジョン受信機に近接して使用されると受信障害を引き起こすことがあります。取り扱い説明書に従って正しい取り扱いをして下さい。

Australia AS/NZS 3548 (1995) - Class B

Australian Contact: SMC Australia
Suite 18, 12 Tryon Road,
Lindfield, NSW 2070
Phone: 61-2-9416-0437
Fax: 61-2-9416-0474

Safety Compliance

UL 1950
CSA 22.2 No. 950
EN60950, (IEC 950)

SPECIFICATIONS

Network Interface

10BASE2
BNC (Thin Coax Cable: RG-58A/U or RG-58C/U)
10BASE-T
RJ-45 (UTP Cable: Categories 3, 4, 5)
100BASE-TX
RJ-45 (UTP Cable: Category 5)

PCI Local Bus Specification

Rev. 2.2

Data Interface

32-bit bus-mastering PCI

I/O Address

Automatically determined by configuration space

Interrupt

INT A, mapping to BIOS IRQ setup

Temperature

0° to 50° C (32° to 122° F)

Humidity

5% to 95% (non-condensing)

Power Consumption

+5 VDC @ 190 mA (standby); @ 250 mA (transmit)
+3.3VDC @ 300 mA (standby)

Size (without bracket)

5.12 x 2.99 in (13.0 x 7.6 cm)

Weight

3.2 oz (90g)

Standards Supported

IEEE 802.3, 802.3u
ACPI
OnNow/PC98

EMC/Safety Compliances

CE Mark
Emmissions
FCC Class B
VCCI Class B
Industry Canada Class B
EN55022 (CISPR 22) Class B
C-Tick - AS/NZS 3548 (1995) Class B
Immunity
IEC 1000-4-2/3/4
Safety
TUV EN60950
UL 1950
CSA 22.2 No. 950

Warranty

Limited Lifetime

Network Drivers

Microsoft drivers
Windows 95/98
Windows NT 3.51, 4.0
Windows 2000
Windows for Workgroups 3.11
LAN Manager v1.x, 2.x
Novell NetWare
NetWare 3.1x, 4.x
32-bit ODI Driver
16-bit DOS ODI Driver
Client32 for Windows 95

SCO

Unix 3.2.4
ODT 5.0

Other

NDIS2 DOS Mode Driver
Packet Driver

REMOTE LAN WAKEUP

Remote LAN Wakeup capability is a key feature of a centrally managed PC environment. This technology allows networked PCs to be powered up and managed from a central location, at any time of the day or night.

To employ Remote LAN Wakeup, three elements are required:

- Desktop management software that can send a "wakeup" packet to a PC.
- A Wake-On-LAN enabled PC motherboard that can supply low-level auxiliary power to a network card when the PC is powered off.
- A Wake-On-LAN network card that can recognize a wake up packet and signal the PC to power up.

A Wake-On-LAN enabled PC is never completely powered off, it maintains a low-level auxiliary power supply to the motherboard. The 3-wire Wake-On-LAN cable provides one line for the network card auxiliary power and one line for the card wakeup signal, the other line is ground. Even if the PC is powered off it's network card is always active and monitoring the network. When a wakeup packet is detected, the card signals the motherboard to power up the PC. With the PC powered on, maintenance and other support tasks can be performed.

CABLE SPECIFICATIONS

Cable Type and Connector

Cable Types and Specifications			
Cable	Type	Max. Length	Connector
10BASE2	RG-58A/U or RG-58C/U 50-ohm thin coax	185 m (607 ft.)	BNC
10BASE-T	Cat. 3, 4, 5 100-ohm UTP	100 m (328 ft.)	RJ-45
100BASE-TX	Cat. 5 100-ohm UTP	100 m (328 ft.)	RJ-45

RJ-45 Connector Pin Assignments

Caution: DO-NOT plug a phone jack connector into any RJ-45 port. Use only twisted-pair cables with RJ-45 connectors that conform with FCC standards.

An Ethernet or Fast Ethernet twisted-pair link segment requires two pairs of wires. Each wire pair must be attached to the RJ-45 connector in the specific orientation detailed below.

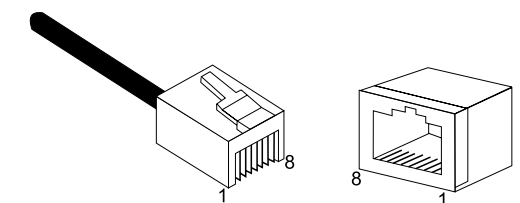

Pin Number	Assignment
1	Output Transmit Data +
2	Output Transmit Data -
3	Input Receive Data +
6	Input Receive Data -
4,5,7,8	Reserved for other use